

▲ Parts List

ITEM	QTY	PART NUMBER	DESCRIPTION
1	1	F060603	LASEEV12
2	1	F060204	25 MM RED LENS
3	1	F051705	30MM FLUSH MOUNT RETAINER
4	1	F051704	30MM FLUSH MOUNT BEZEL
5	1	F050417	LED 6VDC RED

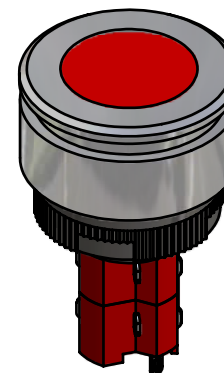

ISOMETRIC

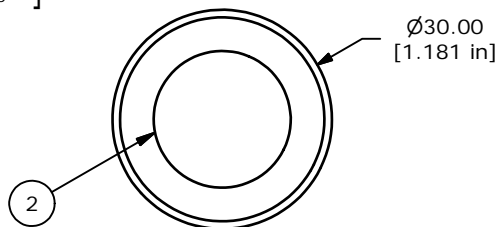
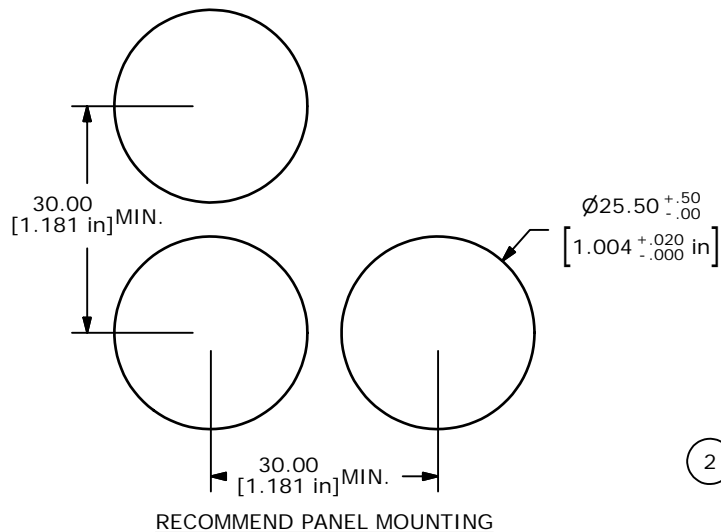
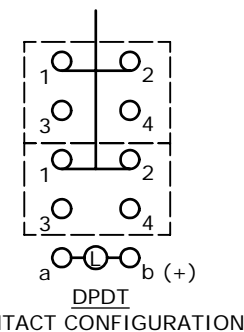
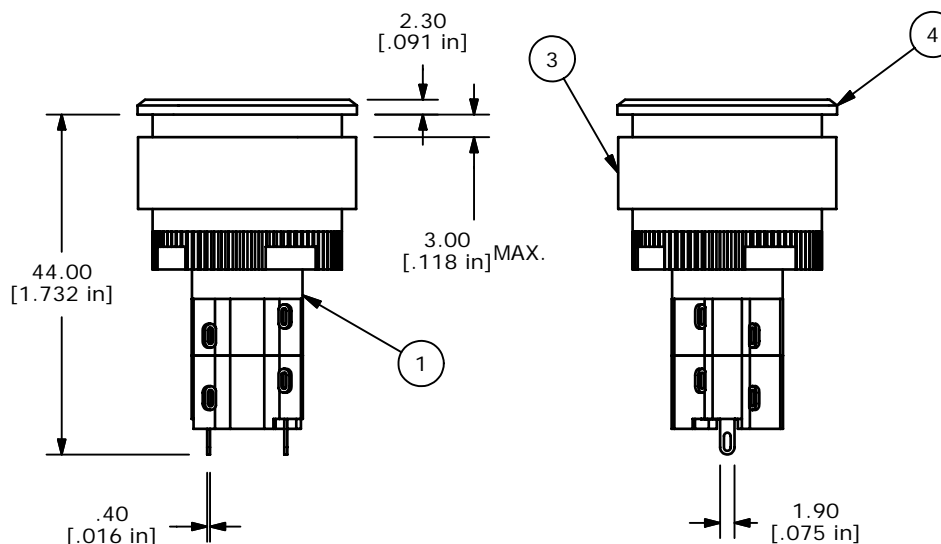

NOTES:

1. ALL DIMENSIONS IN MM [INCH].
2. GENERAL TOLERANCE: 0.0±0.4  
0.00±0.25
3. TERM. NOS. FOR REF. ONLY.
4. RATING: 5A @250VAC  
8A @125VAC  
2A @250VDC  
6A @24VDC
5. INSULATION: 1,000 MΩ MIN.
6. DIELECTRIC STRENGTH: 2000V FOR 1 MIN.
7. SEALED TO IP65.
8. TRAVEL: 3.0MM FULL TRAVEL, 2.0MM LATCH
9. ELECTRICAL LIFE: >50,000 CYCLES
10. OPERATING TEMP: -25C TO +55C
11. PANEL THICKNESS: 0.5MM TO 3.0MM
- ▲12. LAMP VOLTAGE: LED 6V DC RED
13. ▲ DENOTES CRITICAL PARAMETER.
14. PACKAGE: BOX/10 PCS PER.
15. 2002/95/EC (ROHS) COMPLIANT



TITLE LASEEV32HREDRED

B	17552	REVISED AND REDRAWN	8/13/07	BF
REV	PCR NO	DESCRIPTION	DATE	BY

SCALE	DATE	DR	DWG	REV
1:1	8/13/2007	BF	XF0732P	B

THE INFORMATION CONTAINED IN THIS DOCUMENT IS PROPRIETARY TO E-SWITCH AND IS NOT TO BE COPIED OR TRANSFERRED