

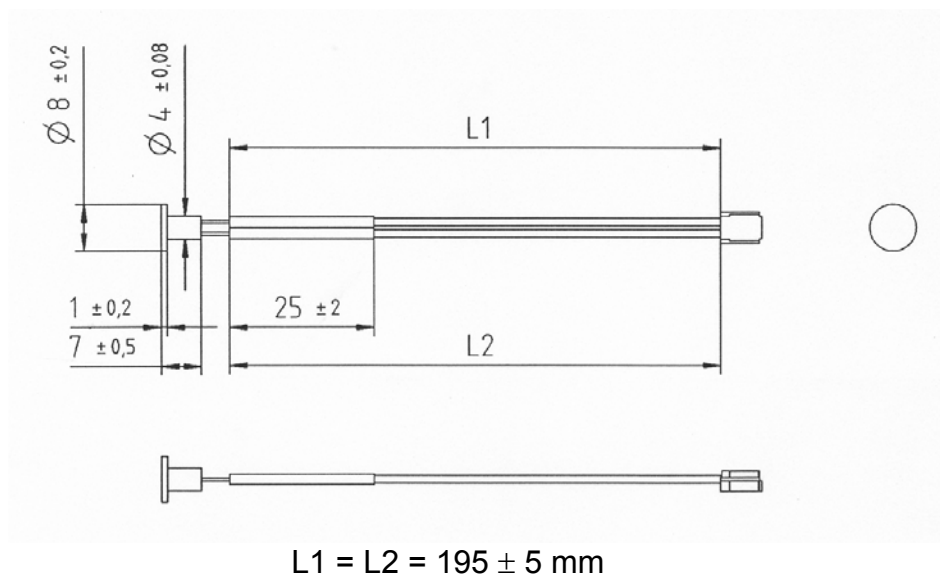

NTC thermistors for temperature measurement

NTC Probes

Series/Type: K560/49k/A1
Ordering code: B57560K0493A001
Date: 2009-04-07
Version: 2

Application:

Surface temperature measurement in household appliances
 e.g.: induction cookers, coffee machines

Version:

Glass encapsulated sensor; mounted in an aluminium housing

Material:

No	Item	Material	Property	Remarks
1	Thermistor	Ceramic	EPCOS NTC G561/49k	glass encapsulated
2	Protecting case	Aluminium		
3	Potting Material	Ceramic	very high temp.	white
4	Wire	Insulation XLPE	AWG26 (7x0,16 mm)	black
5	Shrink tube	Polyolefine	Heatproof 125°C	black
6	Crimp contact	Phosphor bronze	JST SHR-001T-P0.6	tin-plated
7	Connector housing	PA 66	JST HRP-02-S	white (nature)

Ratings and characteristics

Lower category temperature	[°C] :	-10
Upper category temperature for sensor head	[°C] :	+250
Upper category temperature for complete probe *)	[°C] :	+125
Rated resistance R_N // Tolerance	R_N [Ω // %] :	3300 // ± 2,5
Rated temperature	T_N [°C] :	100
B-value : $B_{(0/100)}$ // Tolerance	B_N [K//%] :	3970 // ± 2
R_{25}	[Ω] :	49120
Max power rating at 25°C	P_{25} [mW] :	50
Dissipation factor (in air)	δ_{th} [mW/K] :	appr. 2,2
Thermal time constant (water)	τ_a [s] :	appr. 2
Insulation resistance	R_{is} [MΩ] :	> 100

*) JST connector is specified for a maximum temperature of 85°C

NTC-RESISTANCE-TEMPERATURE-CURVE

R_N at 100°C = 3300 Ω ± 2,5 %

$B(0/100)$ = 3970 K ± 2 %

R at 25°C = 49120 Ω

Temp. [°C]	R min [kΩ]	R nom [kΩ]	R max [kΩ]	ΔR [±%]
-10	242,838	276,061	309,284	12,0
-5	186,662	210,694	234,727	11,4
0	144,687	162,213	179,738	10,8
5	112,917	125,779	138,642	10,2
10	88,812	98,322	107,832	9,7
15	70,375	77,454	84,533	9,1
20	56,162	61,465	66,768	8,6
25	45,124	49,120	53,116	8,1
30	36,489	39,517	42,545	7,7
35	29,690	31,996	34,301	7,2
40	24,301	26,065	27,828	6,8
45	20,003	21,358	22,712	6,3
50	16,555	17,599	18,642	5,9
55	13,772	14,579	15,386	5,5
60	11,515	12,140	12,766	5,2

Temp. [°C]	R min [kΩ]	R nom [kΩ]	R max [kΩ]	ΔR [±%]
65	9,673	10,159	10,645	4,8
70	8,164	8,541	8,919	4,4
75	6,920	7,214	7,508	4,1
80	5,891	6,120	6,349	3,7
85	5,035	5,213	5,392	3,4
90	4,321	4,459	4,597	3,1
95	3,722	3,829	3,936	2,8
100	3,218	3,300	3,382	2,5
105	2,775	2,854	2,934	2,8
110	2,402	2,478	2,554	3,1
115	2,086	2,158	2,230	3,3
120	1,817	1,886	1,954	3,6
125	1,589	1,653	1,717	3,9
130	1,393	1,453	1,513	4,1
135	1,225	1,281	1,337	4,4
140	1,080	1,133	1,185	4,6
145	0,9553	1,004	1,053	4,9
150	0,8472	0,8928	0,9384	5,1
155	0,7532	0,7957	0,8382	5,3
160	0,6713	0,7109	0,7505	5,6
165	0,5999	0,6367	0,6735	5,8
170	0,5372	0,5716	0,6059	6,0
175	0,4823	0,5142	0,5462	6,2
180	0,4339	0,4637	0,4935	6,4
185	0,3912	0,4190	0,4467	6,6
190	0,3534	0,3793	0,4052	6,8
195	0,3200	0,3442	0,3683	7,0
200	0,2903	0,3128	0,3354	7,2
205	0,2638	0,2849	0,3060	7,4
210	0,2402	0,2600	0,2797	7,6
215	0,2191	0,2376	0,2561	7,8
220	0,2003	0,2176	0,2348	7,9
225	0,1833	0,1995	0,2157	8,1
230	0,1681	0,1833	0,1985	8,3
235	0,1544	0,1686	0,1829	8,5
240	0,1420	0,1554	0,1688	8,6
245	0,1308	0,1434	0,1560	8,8
250	0,1207	0,1326	0,1444	8,9

RELIABILITY DATA :

Test	Test conditions	$\Delta R_{25}/R_{25}$ typical	Remarks
Storage in dry heat	Storage at upper category temperature (sensor head) Temperature: 250°C Duration: 1000 h Tested on sensor-elements potted into aluminium housing (without probe assembly)	< 3 %	No visible damage
Storage in coldness	Storage at lower category temperature Temperature: -10°C Duration: 1000 h	< 3 %	No visible damage
Storage in damp, heat, steady state	Temperature of air: 85°C Relative humidity of air: 85% Duration: 56 days	< 3 %	No visible damage
Rapid change of temperature	Lower test temperature: -10°C (time: ~10 min) Upper test temperature: 200°C (time: ~10 min) Time to change from lower to upper temperature: < 30 sec; Number of cycles: 1000 Medium: air Tested on sensor-elements potted into aluminium housing (without probe assembly)	< 3 %	No visible damage
High Voltage test	Apply voltage between aluminium case and sensor: 1000 V _{AC} / 50 Hz / 1sec		No flash over
Insulation test	The sensors are placed in a vessel containing metallic balls of 1 mm diameter (with immersed aluminum case) The applied voltage is 500 V _{DC}		ABOVE 100 MΩ

Cautions and warnings

Storage

- Store thermistors in original packaging only. Do not open the package prior to storage.
- Storage conditions in original packaging: storage temperature $-25^{\circ}\text{C} \dots +45^{\circ}\text{C}$, relative humidity $\leq 75\%$ annual mean, maximum 95%, dew precipitation is inadmissible.
- Do not store thermistors where they are exposed to heat or direct sunlight. Otherwise, the packing material may be deformed or components may stick together, causing problems during mounting.
- Avoid contamination of thermistor surface during storage, handling and processing.
- Avoid storage of thermistors in harmful environments like corrosive gases (SO_x , Cl etc.)
- Use the components as soon as possible after opening the factory seals, i.e. the polyvinyl-sealed packages.
- Solder thermistors within the time specified after shipment from EPCOS.
For leaded components this is 24 months.

Handling

- NTC thermistors must not be dropped. Chip-offs or any other damage must not be caused during handling of NTCs.
- Do not touch components with bare hands. Gloves are recommended.
- Avoid contamination of thermistor surface during handling.

Soldering

- Use resin-type flux or non-activated flux.
- Insufficient preheating may cause ceramic cracks.
- Rapid cooling by dipping in solvent is not recommended.
- Complete removal of flux is recommended.

Mounting

- Ensure that no thermo-mechanical stress occurs due to production processes (curing or overmolding processes) when thermistors are sealed, potted or overmolded or during their subsequent operation. The maximum temperature of the thermistor must not be exceeded. Ensure that the materials used (sealing/potting compound and plastic material) are chemically neutral.
- Electrodes/contacts must not be scratched or damaged before/during/after the mounting process.
- Contacts and housing used for assembly with the thermistor must be clean before mounting.
- Ensure that adjacent materials are designed for operation at temperatures comparable to the surface temperature of the thermistor. Be sure that surrounding parts and materials can withstand the temperature.
- Avoid contamination of the thermistor surface during processing.
- The connections of sensors (e.g. cable end, wire end, plug terminal) may only be exposed to an environment with normal atmospheric conditions.
- Tensile forces on cables or leads must be avoided during mounting and operation.
- Bending or twisting of cables or leads directly on the thermistor body is not permissible.
- Avoid using chemical substances as mounting aids. It must be ensured that no water or other liquids enter the NTC thermistors (e.g. through plug terminals). In particular, water based substances (e.g. soap suds) must not be used as mounting aids for sensors.

Operation

- Use thermistors only within the specified operating temperature range.
- Use thermistors only within the specified power range.
- Environmental conditions must not harm the thermistors. Only use the thermistors under normal atmospheric conditions or within the specified conditions.
- Contact of NTC thermistors with any liquids and solvents should be prevented. It must be ensured that no water enters the NTC thermistors (e.g. through plug terminals). For measurement purposes (checking the specified resistance vs. temperature), the component must not be immersed in water but in suitable liquids (e.g. Galden).
- Avoid dewing and condensation unless thermistor is specified for these conditions.
- Bending or twisting of cables and/or wires is not permissible during operation of the sensor in the application.
- Be sure to provide an appropriate fail-safe function to prevent secondary product damage caused by malfunction.

Important notes

The following applies to all products named in this publication:

1. Some parts of this publication contain **statements about the suitability of our products for certain areas of application**. These statements are based on our knowledge of typical requirements that are often placed on our products in the areas of application concerned. We nevertheless expressly point out **that such statements cannot be regarded as binding statements about the suitability of our products for a particular customer application**. As a rule, EPCOS is either unfamiliar with individual customer applications or less familiar with them than the customers themselves. For these reasons, it is always ultimately incumbent on the customer to check and decide whether an EPCOS product with the properties described in the product specification is suitable for use in a particular customer application.
2. We also point out that **in individual cases, a malfunction of electronic components or failure before the end of their usual service life cannot be completely ruled out in the current state of the art, even if they are operated as specified**. In customer applications requiring a very high level of operational safety and especially in customer applications in which the malfunction or failure of an electronic component could endanger human life or health (e.g. in accident prevention or life-saving systems), it must therefore be ensured by means of suitable design of the customer application or other action taken by the customer (e.g. installation of protective circuitry or redundancy) that no injury or damage is sustained by third parties in the event of malfunction or failure of an electronic component.
3. **The warnings, cautions and product-specific notes must be observed.**
4. In order to satisfy certain technical requirements, **some of the products described in this publication may contain substances subject to restrictions in certain jurisdictions (e.g. because they are classed as hazardous)**. Useful information on this will be found in our Material Data Sheets on the Internet (www.epcos.com/material). Should you have any more detailed questions, please contact our sales offices.
5. We constantly strive to improve our products. Consequently, **the products described in this publication may change from time to time**. The same is true of the corresponding product specifications. Please check therefore to what extent product descriptions and specifications contained in this publication are still applicable before or when you place an order. We also **reserve the right to discontinue production and delivery of products**. Consequently, we cannot guarantee that all products named in this publication will always be available. The aforementioned does not apply in the case of individual agreements deviating from the foregoing for customer-specific products.
6. Unless otherwise agreed in individual contracts, **all orders are subject to the current version of the "General Terms of Delivery for Products and Services in the Electrical Industry" published by the German Electrical and Electronics Industry Association (ZVEI)**.
7. The trade names EPCOS, BAOKE, Alu-X, CeraDiode, CSMP, CSSP, CTVS, DSSP, MiniBlue, MKK, MLSC, MotorCap, PCC, PhaseCap, PhaseCube, PhaseMod, SIFERRIT, SIFI, SIKOREL, SilverCap, SIMDAD, SIMID, SineFormer, SIOV, SIP5D, SIP5K, ThermoFuse, WindCap are **trademarks registered or pending** in Europe and in other countries. Further information will be found on the Internet at www.epcos.com/trademarks.